

SPECIFICATIONS

HW140A L

Powered By Cummins Performance Series Engine

Net Power
170 HP (127 kW)
/ 2,200 rpm

Standard Bucket
.61 m³ / .80 yd³

Operating Weight
35,053 LBS (15,900 kg)



ENGINE		
Maker / Model	CUMMINS / B4.5	
Type	4 cylinder, water cooled, 4-cycle, turbo-charged charge air cooled, direct injection, electronic controlled diesel engine.	
Rated flywheel horse power	SAE J1995 (gross)	129 kW (173 hp) at 2,200 rpm
	J1349 (net)	127 kW (170 hp) at 2,200 rpm
Peak Torque	780 N-m (575 lb.ft) at 1,500 rpm	
Displacement	4.5 l (275 cu in)	
Batteries	2 x 12 V x 100 Ah	
Starting motor	24 V - 4.8 kW	
Alternator	24 V - 95 Amp	

HYDRAULIC SYSTEM		
MAIN PUMP		
Type	Variable Displacement Piston pumps	
Max. Flow	232 l/pm (61.29 gmp) @ 1,600 rpm	
AUXILIARY PRESSURE		
2 Way	Flow (l/min)	13~58 gpm / (50~220 lpm)
	Pressure (bar)	1,450~4,641 psi / (100~320 bar)
Rotating	Flow (l/min)	16 gpm / (60 lpm)
	Pressure (bar)	3,046 psi / (210 bar)

PILOT PUMP	
Type	Fixed displacement gear pump single stage
Max. Flow	28.5 l /min (7.5 U.S. gpm)

HYDRAULIC MOTORS	
Travel	Variable Displacement Bent Axis Piston Motor
Swing	Radial Piston Motor

RELIEF VALVE SETTING	
Implement Circuits	350 kgf/cm ² (4,970 psi)
Travel	380 kgf/cm ² (5,400 psi)
Power Boost (Boom, Arm, Bucket)	380 kgf/cm ² (5,400 psi)
Swing Circuit	285 kgf/cm ² (4,050 psi)
Pilot Circuit	40 kgf/cm ² (570 psi)
Service Valve	Installed

DRIVES & BRAKES	
4-wheel hydrostatic drive. Constant mesh, helical gear transmission provides 2 forward and reverse travel speeds.	
Reduction System	Planetary reduction gear
Max. Drawbar Pull	10,720 kgf (23,634 lbf)
Max. Travel Speed (High / Low)	10 km/hr (6.2 mph) / 39 km/hr (24.2 mph)
Gradeability	35° (70%)
Parking Brake	Spring applied and hydraulic released wet disc brake type in transmission.

OPERATING WEIGHT (APPROXIMATE)

Operating weight, including 4,600mm (15' 1") Mono boom, 2,450mm (8' 0") Arm, SAE heaped 0.61 m³ (0.80 yd³) bucket, lubricant, coolant, full fuel tank, hydraulic tank and the standard equipment.

OPERATING WEIGHT		
	Mono boom	2-Piece boom
Rear outrigger	14,900 kg (32,850 lb)	15,860 kg (34,960 lb)
Front outrigger and rear blade	15,120 kg (33,330 lb)	16,080 kg (35,450 lb)
Front blade and rear outrigger	15,900 kg (35,050 lb)	16,860 kg (37,170 lb)
Four outrigger	15,830 kg (34,900 lb)	16,790 kg (37,010 lb)
Front blade and rear blade	16,120 kg (35,540 lb)	17,080 kg (37,650 lb)

SWING SYSTEM

Swing motor	Fixed Displacement Axial Piston Motor
Swing bearing lubrication	Grease-bathed
Swing brake	Multi wet disc
Swing speed	9.5 rpm

COOLANT & LUBRICANT CAPACITY

	US gal	liter	
Fuel Tank	66.0	250	
Engine Coolant	5.2	19.5	
Engine Oil	2.9	11	
Swing Device	Gear Oil (Opt)	1.32	5.0
	Grease Oil (Opt)	0.32	1.2
Axle	Front	4	15.5
	Rear	4.6	17.5
Transmission	0.66	2.5	
Hydraulic System (Including Tank)	53.9	204	
Hydraulic Tank	32.2	122	
Def/Adblue®	7.1	27	

UNDERCARRIAGE

Reinforced box-section frame is all-welded, low-stress. Dozer blade and outrigger options are available. Easily replaceable through bolt-on design.

Dozer blade	Parallelogram-mounted dozer blade to support machine when working, also for leveling and back filling.
Outriggers	Indicated for max. operation stability when digging and lifting. Can be mounted on front/or rear.

CAB NOISE LEVEL

Guaranteed noise level presented below can be differed depending on a range of factors such as operating condition, speed of a cooling fan, types of engine and so forth. Hearing protection shall be necessary if an operator is working in the improperly aintained cabin or exposed to a noisy environment by leaving doors and/or windows open. With cooling fan speed at maximum value:

Operator sound pressure level (ISO 6396:2008)	71 dB(A)
Exterior sound power level (ISO 6395:2008)	99 dB(A)

* Distance of 15 m (49.2 ft), moving forward in second gear ratio

CONTROL

Pilot pressure operated joysticks and pedals with detachable lever provide almost effortless and fatigueless operation.

Pilot Control	Two joysticks with one safety lever (LH) : Swing and arm, (RH) : Boom and bucket
FNR switch on RH joystick / Ram lock switch on LH joystick	
Attachment Control	3 modes available: Push / Proportional / Permanent
Engine Throttle	Electric, Dial type
Operation Mode	3 modes available: P-Parking W-Working T-Travel

SPECIFICATIONS HW140A L

EU Stage V Engine Installed

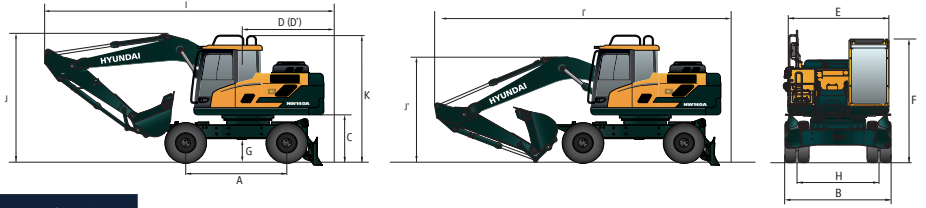

HW140A L MONO BOOM DIMENSIONS

Unit: ft·in (mm)

4.6 m (15' 1") Mono boom, 2.0 m (6' 7"), 2.45 m (8' 0"), 2.6 m (8' 6"), 3.1 m (10' 2") Arm, Rear dozer

A	Wheel base	2,600 (8' 6")
B	Overall width (STD)	2,530 (8' 4")
C	Ground clearance of counterweight	1,260 (4' 2")
D	Rear-end distance	2,150 (7' 0")
D'	Rear-end swing radius	2,170 (7' 1")
E	Upperstructure width	2,485 (8' 2")
F	Overall height of cab	3,255 (10' 8")
G	Min. ground clearance	390 (1' 3")
H	Tread	1,944 (6' 5")
K	Overall height of guardrail	3,475 (11' 5")

	Arm length	2,000 (6' 7")	2,450 (8' 0")	2,600 (8' 6")	3,100 (10' 2")
I	Overall length (Traveling position)	7,665 (25' 2")	7,485 (24' 7")	7,395 (24' 3")	7,290 (23' 11")
I'	Overall length (Shipping position)	7,590 (24' 11")	7,660 (25' 2")	7,670 (25' 2")	7,600 (24' 11")
J	Overall height of boom (Traveling position)	3,270 (10' 9")	3,655 (12' 0")	3,775 (12' 5")	3,990 (13' 1")
J'	Overall height of boom (Shipping position)	2,725 (8' 11")	2,930 (9' 7")	3,050 (10' 0")	3,420 (11' 3")

HW140A L MONO BOOM WORKING RANGE

Unit: ft·in (mm)

Boom length	4,600 (15' 1")			
Arm length	2,000 (6' 7")	2,450 (8' 0")	2,600 (8' 6")	3,100 (10' 2")
A Max. digging reach	7,880 (25' 10")	8,310 (27' 3")	8,450 (27' 9")	8,910 (29' 3")
A' Max. digging reach on ground	7,640 (25' 1")	8,080 (26' 6")	8,230 (27' 0")	8,700 (28' 7")
B Max. digging depth	4,660 (15' 3")	5,110 (16' 9")	5,260 (17' 3")	5,760 (18' 11")
B' Max. digging depth (8' level)	4,400 (14' 5")	4,895 (16' 1")	5,060 (16' 7")	5,580 (18' 4")
C Max. vertical wall digging depth	4,200 (13' 9")	4,655 (15' 3")	4,800 (15' 9")	5,310 (17' 5")
D Max. digging height	8,540 (28' 0")	8,850 (29' 0")	8,940 (29' 4")	9,210 (30' 3")
E Max. dumping height	6,100 (20' 0")	6,400 (21' 0")	6,490 (21' 4")	6,760 (22' 2")
F Min. swing radius	2,670 (8' 9")	2,680 (8' 10")	2,690 (8' 10")	2,720 (8' 11")

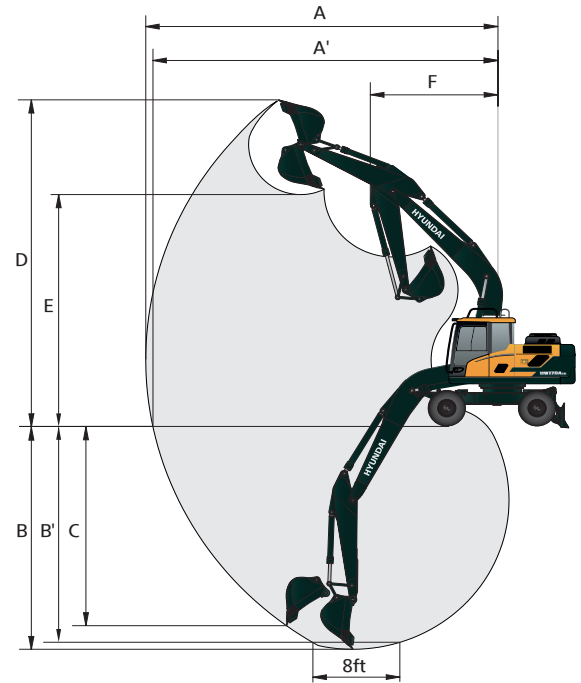

DIGGING FORCE

Boom	Length	mm (ftin)	4,600 (15' 1") Mono				Remark
Arm	Length	mm (ftin)	2,000 (6' 7")	2,450 (8' 0")	2,600 (8' 6")	3,100 (10' 2")	
Bucket digging force	SAE	kN	88 [96]	88 [96]	88 [96]	88 [96]	[] : Power Boost
		kgf	8,957 [9,770]	8,961 [9,780]	8,961 [9,780]	8,956 [9,770]	
		lbf	19,750 [21,540]	19,760 [21,560]	19,760 [21,560]	19,750 [21,540]	
	ISO	kN	103 [112]	103 [112]	103 [112]	103 [112]	
		kgf	10,489 [11,440]	10,494 [11,450]	10,494 [11,450]	10,489 [11,440]	
		lbf	23,130 [25,220]	23,140 [25,240]	23,140 [25,240]	23,120 [25,220]	
Arm crowd force	SAE	kN	74 [81]	64 [69]	61 [67]	55 [60]	
		kgf	7,569 [8,260]	6,485 [7,070]	6,230 [6,800]	5,579 [6,090]	
		lbf	16,690 [18,120]	14,300 [15,590]	13,740 [14,990]	12,300 [13,430]	
	ISO	kN	78 [85]	66 [72]	64 [69]	57 [62]	
		kgf	7,942 [8,660]	6,764 [7,380]	6,486 [7,080]	5,782 [6,310]	
		lbf	17,510 [19,090]	14,910 [16,270]	14,300 [15,610]	12,750 [13,910]	

Note : Arm weight includes bucket cylinder, linkage, and pin

SPECIFICATIONS HW140AL

EU Stage V Engine Installed

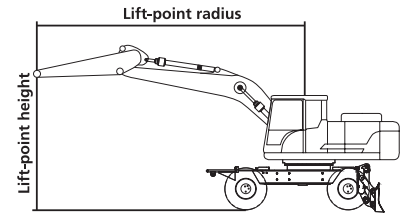

Lifting Capacity (Dozer Up)

Boom: 4.6 m (15' 1")

Arm: 2.0 m (6' 7")

CWT 3,250 kg (7,170 lb)

Capacities based on North American Standard Configuration
in accordance with ISO condition 2 standard.

Rating over front

Rating over side or 360 degree

Lift-point height m (ft)	Lift-point radius								At max. reach			
	1.5 m (4.9 ft)		3.0 m (9.8 ft)		4.5 m (14.8 ft)		6.0 m (19.7 ft)		Capacity		Reach m (ft)	
6.0 m 19.7 ft	kg lb					*3,880 *8,550	3 390 7 470			*2,390 *5,270	2,250 4,960	5.70 (18.7)
4.5 m 14.8 ft	kg lb					*4 330 *9,550	3,280 7,230	3,590 7910	2,050 4,520	*2,250 *4,960	1,750 3,860	6.55 (21.5)
3.0 m 9.8 ft	kg lb			*7 850 *17,310	5,600 12,350	*5,330 *11,750	3,050 6,720	3,500 7,720	1 970 4,340	*2,260 *4,980	1,530 3,370	6.97 (22.9)
1.5 m 4.9 ft	kg lb			*5,690 *12,540	4,970 10,960	5,270 11,620	2,810 6,190	3,390 7,470	1,860 4,100	*2,410 *5,310	1,460 3,220	7.05 (23.1)
Ground Line	kg lb			*6,760 *14,900	4,790 10,560	5,100 11,240	2,670 5,890	3,310 7,300	1,790 3,950	*2,740 *6 040	1,510 3,330	6.79 (22.3)
-1.5 m -4.9 ft	kg lb	*5,600 *12,350	*5,600 *12,350	*9 980 *22,000	4,800 10,580	5,060 11,160	2,640 5,820	3,300 7,280	1,790 3,950	3,190 7,030	1,730 3,810	6.16 (20.2)
-3.0 m -9.8 ft	kg lb			*7,990 *17,610	4 940 10,890	5,160 11,380	2,720 6,000			4,400 9,700	2,370 5,220	5.01 (16.4)

Lifting Capacity (Dozer Down)

Boom: 4.6 m (15' 1")

Arm: 2.0 m (6' 7")

CWT 3,250 kg (7,170 lb)

Capacities based on North American Standard Configuration
in accordance with ISO condition 2 standard.

Rating over front

Rating over side or 360 degree

Lift-point height m (ft)	Lift-point radius								At max. reach			
	1.5 m (4.9 ft)		3.0 m (9.8 ft)		4.5 m (14.8 ft)		6.0 m (19.7 ft)		Capacity		Reach m (ft)	
6.0 m 19.7 ft	kg lb					*3,880 *8,550	3,740 8,250			*2,390 *5,270	*2,390 *5,270	5.70 (18.7)
4.5 m 14.8 ft	kg lb					*4,330 *9,550	3,620 7,980	3,590 7910	2,270 5,000	*2,250 *4,960	1,940 4,280	6.55 (21.5)
3.0 m 9.8 ft	kg lb			*7,850 *17,310	6,310 13,910	*5,330 *11,750	3,390 7,470	3,500 7,720	2,180 4,810	*2,260 *4,980	1,700 3,750	6.97 (22.9)
1.5 m 4.9 ft	kg lb			*5,690 *12,540	5,650 12,460	5,270 11,620	3,150 6,940	3,390 7,470	2,080 4,590	*2,410 *5,310	1,630 3,590	7.05 (23.1)
Ground Line	kg lb			*6,760 *14 900	5,460 12,040	5,100 11,240	3,000 6,610	3,310 7,300	2,010 4,430	*2,740 *6,040	1,690 3,730	6.79 (22.3)
-1.5 m -4.9 ft	kg lb	*5,600 *12,350	*5,600 *12,350	*9,980 *22,000	5,480 12,080	5,060 11,160	2,960 6,530	3,300 7,280	2,000 4,410	3,190 7,030	1,940 4,280	6.16 (20.2)
-3.0 m -9.8 ft	kg lb			*7 990 *17,610	5,620 12,390	5,160 11,380	3,050 6,720			4,400 9,700	2,650 5,840	5.01 (16.4)

NOTES:

- Lifting capacities are based on ISO 10567.
- Lifting capacity of the HW Series does not exceed 75% of tipping load with the machine on firm, level ground or 87% of full hydraulic capacity.

- The Lift-point is bucket pivot mounting pin on the arm (without bucket mass).
- (*) indicates load limited by hydraulic capacity.

ENGINE	STD	OPT
Cummins B4.5 engine	●	
HYDRAULIC SYSTEM		
Intelligent Power Control (IPC)		
3-power mode, 2-work mode, user mode	●	
Variable Power Control	●	
Pump Flow Control	●	
Attachment Mode Flow Control	●	
Engine Auto Idle	●	
Engine Auto Shutdown Control	●	
Electronic Fan Control	●	
20 km/h speed limit		●
Hyundai Bio Hydraulic Oil (HBHO)		●
CAB & INTERIOR		
ISO Standard cabin		
Rise-up type windshield wiper	●	
Radio / USB player	●	
Handsfree mobile phone system with USB	●	
12 volt power outlet (24V DC to 12V DC converter)	●	
Electric horn	●	
All-weather steel cab with 360° visibility	●	
Safety glass - Tempered glass with front laminated glass	●	
Safety glass windows	●	
Sliding fold-in front window	●	
Sliding side window(LH)	●	
Lockable door	●	
Hot & cool box	●	
Storage compartment	●	
Transparent cabin roof-cover	●	
Sun visor	●	
Door and cab locks, one key	●	
Mechanical suspension seat with heater	●	
Pilot-operated slidable joystick	●	
Console box height adjust system	●	
Automatic climate control		
Air conditioner & heater	●	
Defroster	●	
Starting Aid (air grid heater) for cold weather	●	
Centralized monitoring		
8" LCD display	●	
Engine speed or Trip meter/Accel.	●	
Engine coolant temperature gauge	●	
Max power	●	
Low speed/High speed	●	
Auto idle	●	
Overload warning with alarm		●
Check Engine	●	
Air cleaner clogging	●	
Indicators	●	
ECO Gauges	●	
Fuel level gauge	●	
Hyd. oil temperature gauge	●	
Warnings	●	
Communication error	●	
Low battery	●	
Clock	●	
Cabin lights		●
Cabin front window rain guard		●
Seat		
Adjustable air suspension with heater		●
Cabin FOG (ISO 10,262) Level 2		
FOPS	Front & Tops Guard	●
(Falling Object Structures)	Top Guard	●
Cabin ROPS (ISO 12,117-2)		
ROPS (Roll Over Protective Structures)	●	

SAFETY	STD	OPT
Ride control & Boom floating		●
Radar with 2nd monitor		●
Battery master switch	●	
Rear view camera	●	
Rear & Mirror view camera		●
AAVM (Advanced Around View Monitoring)		●
Four front working lights (2 boom mounted, 2 front frame mounted)	●	
Travel alarm	●	
Rear work lamp		●
Beacon lamp		●
Automatic swing brake	●	
Boom holding system	●	
Arm holding system	●	
Safety lock valve for boom cylinder with overload warning device	●	
Safety lock valve for arm cylinder	●	
Swing Lock System		●
Four outside rearview mirror	●	
ATTACHMENT		
Booms		
4.10 m, 13' 5" Mono		●
4.60 m, 15' 1" Mono	●	
4.71 m, 15' 5" 2-Piece		●
Arms		
2.00 m, 6' 7"		●
2.45 m, 8' 0"	●	
2.60 m, 8' 6"		●
3.10 m, 10' 2"		●
OTHER		
Heavy CWT		●
Fuel pre-filter	●	
Self-diagnostics system	●	
Hi MATE (Remote Management System)	●	
Batteries (2 x 12V x 100 AH)	●	
Fuel filler pump (35 lpm)	●	
Double-acting piping kit with fingertip control	●	
Rotating Piping Kit		●
Quick coupler piping	●	
Quick coupler	●	
Accumulator for lowering work equipment	●	
Pattern change valve (2 patterns)		●
Fine Swing Control System		●
Automatic braking		●
Joystick Steering		●
Auto cruiser system	●	
LED lights on boom (2)		●
Lower Frame Toolbox - LH	●	
Lower Frame Toolbox - LH, RH		●
UNDERCARRIAGE		
Front dozer blade		●
Rear dozer blade		●
Rear outrigger		●
Front outrigger and rear blade	●	
Front and rear outrigger		●
Front blade and rear outrigger		●
Front grapple rest and rear blade		●
Trailer hitch for rear dozer blade		●
Front grapple rest and rear outrigger		●
Front bucket rest and rear blade		●
Front bucket rest and rear outrigger		●
Tires- dual (9,00-20-14PR tube)	●	
Tires- dual (9,00-20 solid)		●
Tires- dual (10,00-20-14PR tube)		●
Fenders (Mudguards)		●

* Standard and optional equipment may vary. Contact your Hyundai dealer for more information.
 The machine may vary according to International standards.
 * The photos may include attachments and optional equipment that are not available in your area.
 * Materials and specifications are subject to change without advance notice.
 * All imperial measurements rounded off to the nearest pound or inch.

PLEASE CONTACT